

10", Steel Frame
1.4" PESVW Voice Coil, Aluminum Former
Paper Cone, Rubber Surround, Long Excursion(±5mm)
Strong Ferrite Magnet Motor System
Pole Piece Vent, Low Distortion(<3%)

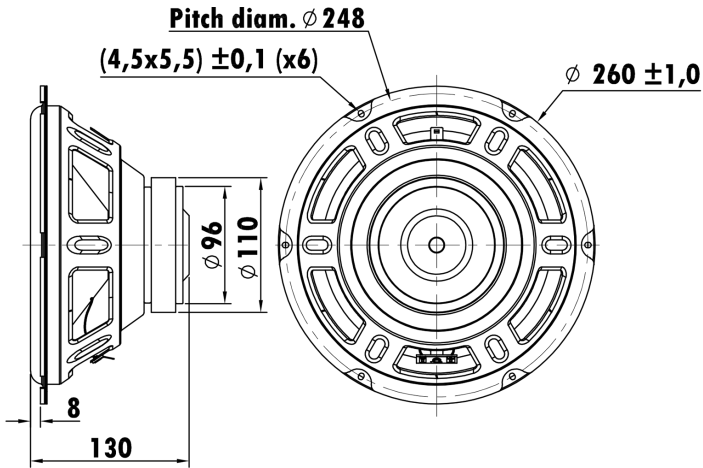

T-S Parameters

Resonance frequency [fs]	31 Hz
Mechanical Q factor [Qms]	5.64
Electrical Q factor [Qes]	0.475
Total Q factor [Qts]	0.438
Force factor [Bl]	9.336 Tm
Mechanical resistance [Rms]	2.14 kg/s
Moving mass [Mms]	61.355 g
Compliance [Cms]	0.421 mm/N
Effective diaph. diameter [D]	210 mm
Effective piston area [Sd]	346.36 cm ²
Equivalent volume [Vas]	71.523 l
Sensitivity (2.83V/1m)	91 dB
Ratio Bl/√Re	5.04 N/√W
Ratio fs/Qts	70.78 Hz

Electrical Data

Nominal impedance [Zn]	4 Ω
Minimum impedance [Zmin]	3.21 Ω
Maximum impedance [Zo]	26.48 Ω
DC resistance [Re]	3.43 Ω
Voice coil inductance [Le]	1.3 mH

Power Handling

100h RMS noise test (IEC 17.1)	60 W
Long-term max power (IEC 17.3)	- W

Voice Coil & Magnet Data

Voice coil diameter	35.5 mm
Voice coil height	16 mm
Voice coil layers	4
Height of gap	6 mm
Linear excursion	± 5 mm
Max mech. excursion	± - mm
Unit weight	2.09 kg

