

1.75" x 4" Racetrack Steel Frame  
 0.6" PESVCCA W Voice Coil, Aluminum Former  
 Paper Cone, Rubber Surround  
 Rectangle Ferrite Magnet Motor System  
 For TV or Soundbar Product

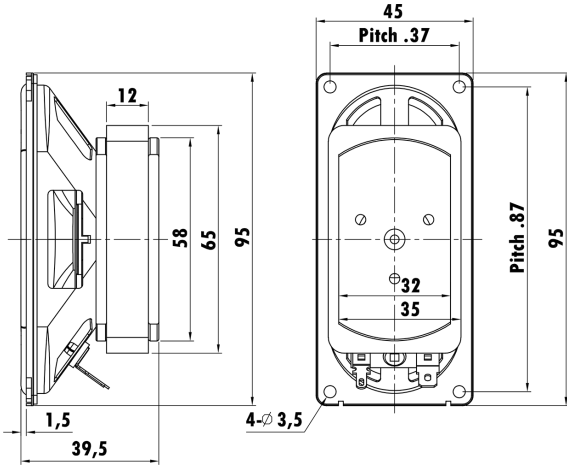

### T-S Parameters

Resonance frequency [fs]	127.7 Hz
Mechanical Q factor [Qms]	5.980
Electrical Q factor [Qes]	1.228
Total Q factor [Qts]	1.019
Force factor [Bl]	2.870 Tm
Mechanical resistance [Rms]	0.437 kg/s
Moving mass [Mms]	3.253 g
Compliance [Cms]	0.477 mm/N
Effective diaph. diameter [D]	34x83 mm
Effective piston area [Sd]	25.31 cm <sup>2</sup>
Equivalent volume [Vas]	0.4327 l
Sensitivity (2.83V/1m)	86 dB
Ratio Bl/√Re	1.457 N/√W
Ratio fs/Qts	125.3 Hz

### Electrical Data

Nominal impedance [Zn]	4 Ω
Minimum impedance [Zmin]	4.194 Ω
Maximum impedance [Zo]	17.502 Ω
DC resistance [Re]	3.88 Ω
Voice coil inductance [Le]	0.243 mH

### Power Handling

100h RMS noise test (IEC 17.1)	8 W
Long-term max power (IEC 17.3)	- W

### Voice Coil & Magnet Data

Voice coil diameter	16.28 mm
Voice coil height	8.0 mm
Voice coil layers	4
Height of gap	3 mm
Linear excursion	± 2.5 mm
Max mech. excursion	± - mm
Unit weight	0.248 kg

