

6.5", Steel Frame
 1.2"1-EISVW Voice Coil, Aluminum Former
 Paper Cone, Rubber Surround
 Strong Ferrite Magnet Motor System
 High Sensitivity

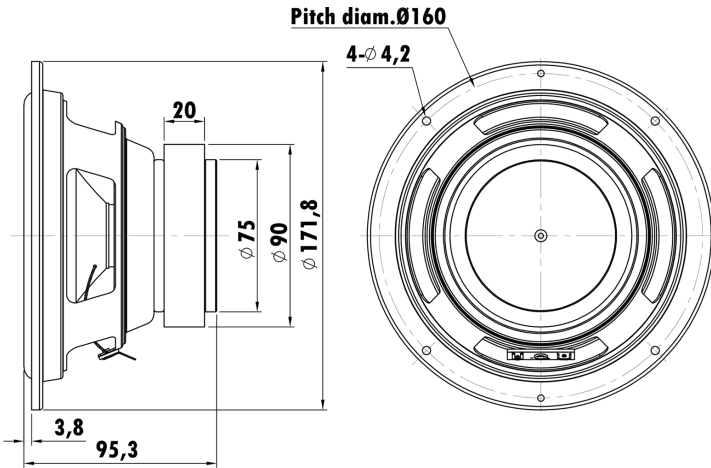

T-S Parameters

Resonance frequency [fs]	61.4 Hz
Mechanical Q factor [Qms]	4.924
Electrical Q factor [Qes]	0.863
Total Q factor [Qts]	0.734
Force factor [Bl]	5.499 Tm
Mechanical resistance [Rms]	1.535 kg/s
Moving mass [Mms]	19.58 g
Compliance [Cms]	0.343 mm/N
Effective diaph. diameter [D]	129.1 mm
Effective piston area [Sd]	130.9 cm ²
Equivalent volume [Vas]	8.3147 l
Sensitivity (2.83V/1m)	90 dB
Ratio Bl/√Re	2.96 N/√W
Ratio fs/Qts	83.651 Hz

Electrical Data

Nominal impedance [Zn]	4 Ω
Minimum impedance [Zmin]	3.784 Ω
Maximum impedance [Zo]	18.37 Ω
DC resistance [Re]	3.45 Ω
Voice coil inductance [Le]	0.397 mH

Power Handling

100h RMS noise test (IEC 17.1)	30 W
Long-term max power (IEC 17.3)	- W

Voice Coil & Magnet Data

Voice coil diameter	30.5 mm
Voice coil height	14.4 mm
Voice coil layers	2
Height of gap	5 mm
Linear excursion	± 4.7 mm
Max mech. excursion	± - mm
Unit weight	1.15 kg

