

0.7", Plastic Frame
0.7" CCAW Voice Coil, Aluminum Former
Titanium Dome with Silk Surround
Neodymium Magnet Motor System
High Sensitivity
Power Handling with 4th HP Filter @1500Hz

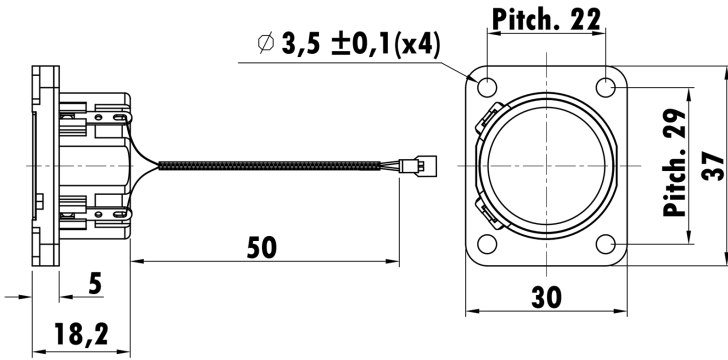

T-S Parameters

Resonance frequency [fs]	1208 Hz
Mechanical Q factor [Qms]	2.211
Electrical Q factor [Qes]	1.613
Total Q factor [Qts]	0.933
Force factor [Bl]	2.135 Tm
Mechanical resistance [Rms]	0.923 kg/s
Moving mass [Mms]	0.269 g
Compliance [Cms]	0.065 mm/N
Effective diaph. diameter [D]	22 mm
Effective piston area [Sd]	3.8 cm ²
Equivalent volume [Vas]	0.0013 l
Sensitivity (2.83V/1m)	88 dB
Ratio Bl/√Re	1.125 N/√W
Ratio fs/Qts	1294.86 Hz

Electrical Data

Nominal impedance [Zn]	4 Ω
Minimum impedance [Zmin]	3.9 Ω
Maximum impedance [Zo]	8.5 Ω
DC resistance [Re]	3.6 Ω
Voice coil inductance [Le]	0.024 mH

Power Handling

100h RMS noise test (IEC 18.4)	5 W
Long-term max power (IEC 18.2)	- W

Voice Coil & Magnet Data

Voice coil diameter	18.4 mm
Voice coil height	2.6 mm
Voice coil layers	2
Height of gap	2 mm
Linear excursion	± 0.3 mm
Max mech. excursion	± - mm
Unit weight	0.041 kg

