

0.6", Plastic Frame
0.6" CCAW Voice Coil, Aluminum Former
Textile Dome Diaphragm
Dual Neodymium Magnet Motor System
High Sensitivity
Power Handling with 4th HP Filter @2500Hz

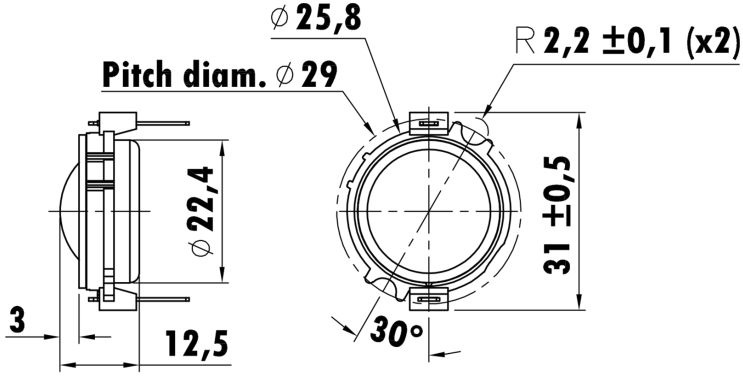

T-S Parameters

Resonance frequency [fs]	2530 Hz
Mechanical Q factor [Qms]	2.37
Electrical Q factor [Qes]	5.92
Total Q factor [Qts]	1.69
Force factor [Bl]	1.6 Tm
Mechanical resistance [Rms]	0.86 kg/s
Moving mass [Mms]	0.13 g
Compliance [Cms]	0.03 mm/N
Effective diaph. diameter [D]	19.3 mm
Effective piston area [Sd]	2.93 cm ²
Equivalent volume [Vas]	0.002 l
Sensitivity (2.83V/1m)	85 dB
Ratio Bl/√Re	0.58 N/√W
Ratio fs/Qts	1497 Hz

Electrical Data

Nominal impedance [Zn]	8 Ω
Minimum impedance [Zmin]	6.8 Ω
Maximum impedance [Zo]	9.8 Ω
DC resistance [Re]	7.5 Ω
Voice coil inductance [Le]	0.028 mH

Power Handling

100h RMS noise test (IEC 18.4)	25 W
Long-term max power (IEC 18.2)	- W

Voice Coil & Magnet Data

Voice coil diameter	16.4 mm
Voice coil height	1.6 mm
Voice coil layers	2
Height of gap	1.5 mm
Linear excursion	± 0.05 mm
Max mech. excursion	± - mm
Unit weight	0.0219 kg

