

152.5mm x 96.4mm, Steel Frame  
1" Dual PESVW Voice Coil, Kapton Former  
Paper Cone, Rubber Surround  
Ferrite Magnet Motor System

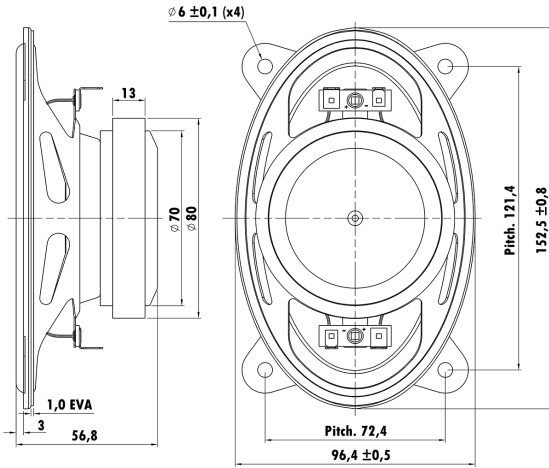

### T-S Parameters

Resonance frequency [fs]	60.6 Hz
Mechanical Q factor [Qms]	2.508
Electrical Q factor [Qes]	0.469
Total Q factor [Qts]	0.395
Force factor [Bl]	4.26 Tm
Mechanical resistance [Rms]	1.827 kg/s
Moving mass [Mms]	12.03 g
Compliance [Cms]	0.574 mm/N
Effective diaph. diameter [D]	131x78.7 mm
Effective piston area [Sd]	80.97 cm <sup>2</sup>
Equivalent volume [Vas]	5.8396 l
Sensitivity (2.83V/1m)	86 dB
Ratio Bl/√Re	3.13 N/√W
Ratio fs/Qts	153.4 Hz

### Electrical Data

Nominal impedance [Zn]	4 Ω
Minimum impedance [Zmin]	4.192 Ω
Maximum impedance [Zo]	12.294 Ω
DC resistance [Re]	1.86 Ω
Voice coil inductance [Le]	0.27 mH

### Power Handling

100h RMS noise test (IEC 18.4)	20 W
Long-term max power (IEC 18.2)	- W

### Voice Coil & Magnet Data

Voice coil diameter	25.4 mm
Voice coil height	9.5 mm
Voice coil layers	4
Height of gap	5 mm
Linear excursion	± 2.25 mm
Max mech. excursion	± - mm
Unit weight	0.635 kg

