

8", Steel Frame
1.4" 1-EISVW Voice Coil, Aluminum Former
Paper Cone, Rubber Surround
Ferrite Magnet Motor System
High Sensitivity
Power Handling with 4th HP Filter @30Hz

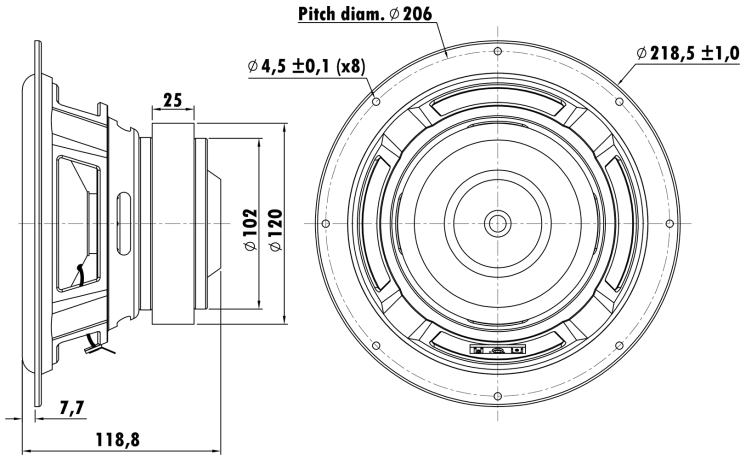

T-S Parameters

Resonance frequency [fs]	44 Hz
Mechanical Q factor [Qms]	2.94
Electrical Q factor [Qes]	0.64
Total Q factor [Qts]	0.52
Force factor [Bl]	7.92 Tm
Mechanical resistance [Rms]	4.91 kg/s
Moving mass [Mms]	52.2 g
Compliance [Cms]	0.25 mm/N
Effective diaph. diameter [D]	160 mm
Effective piston area [Sd]	201.06 cm ²
Equivalent volume [Vas]	14.28 l
Sensitivity (2.83V/1m)	89 dB
Ratio Bl/ \sqrt{Re}	4.74 N/ \sqrt{W}
Ratio fs/Qts	84.61 Hz

Electrical Data

Nominal impedance [Zn]	3 Ω
Minimum impedance [Zmin]	3.1 Ω
Maximum impedance [Zo]	13.351 Ω
DC resistance [Re]	2.78 Ω
Voice coil inductance [Le]	0.94 mH

Power Handling

100h RMS noise test (IEC 18.4)	250 W
Long-term max power (IEC 18.2)	- W

Voice Coil & Magnet Data

Voice coil diameter	35.5 mm
Voice coil height	25.3 mm
Voice coil layers	4
Height of gap	8 mm
Linear excursion	± 8.65 mm
Max mech. excursion	\pm - mm
Unit weight	2.740 kg

