

5.25", Steel Frame
1.2", PESVW Voice Coil, Kapton Former
Paper Cone, Rubber Surround
Strong Ferrite Magnet Motor System

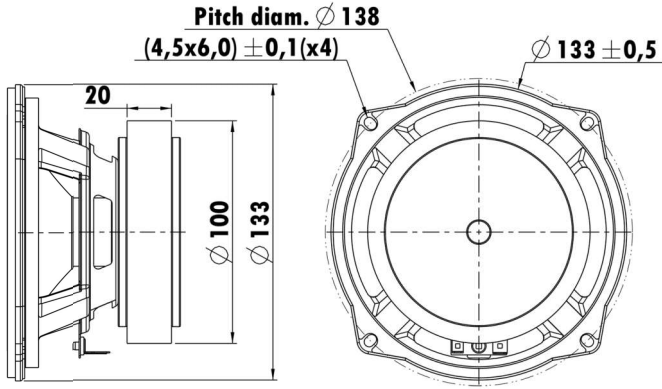

T-S Parameters

Resonance frequency [fs]	59.8 Hz
Mechanical Q factor [Qms]	7.16
Electrical Q factor [Qes]	0.52
Total Q factor [Qts]	0.49
Force factor [Bl]	8.05 Tm
Mechanical resistance [Rms]	1.35 kg/s
Moving mass [Mms]	25.81 g
Compliance [Cms]	0.28 mm/N
Effective diaph. diameter [D]	133 mm
Effective piston area [Sd]	88.25 cm ²
Equivalent volume [Vas]	3.03 l
Sensitivity (2.83V/1m)	87 dB
Ratio Bl/√Re	1.16 N/√W
Ratio fs/Qts	122.04 Hz

Electrical Data

Nominal impedance [Zn]	4 Ω
Minimum impedance [Zmin]	3.9 Ω
Maximum impedance [Zo]	37 Ω
DC resistance [Re]	3.50 Ω
Voice coil inductance [Le]	0.82 mH

Power Handling

100h RMS noise test (IEC 18.4)	40 W
Long-term max power (IEC 18.2)	- W

Voice Coil & Magnet Data

Voice coil diameter	30.50 mm
Voice coil height	12.5 mm
Voice coil layers	4
Height of gap	4 mm
Linear excursion	± 4.25 mm
Max mech. excursion	± - mm
Unit weight	1.172 kg

