

6", Steel Frame
 1.2"1-PESVW Voice Coil, Aluminum Former
 Paper Cone, Rubber Surround
 Strong Ferrite Magnet Motor System
 High Sensitivity

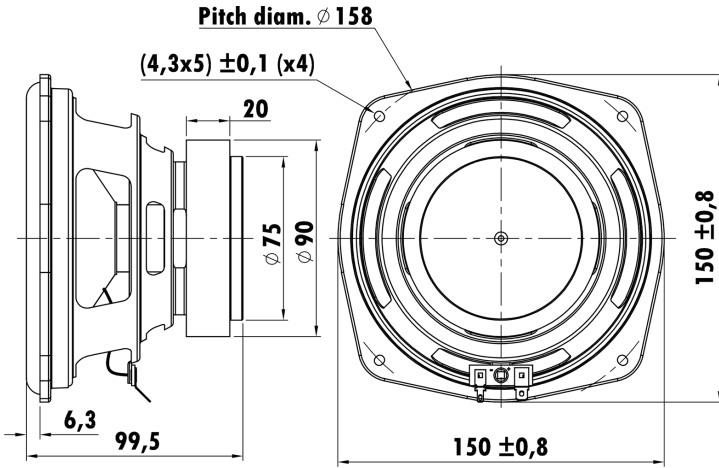

T-S Parameters

Resonance frequency [fs]	65.5 Hz
Mechanical Q factor [Qms]	7.743
Electrical Q factor [Qes]	0.889
Total Q factor [Qts]	0.797
Force factor [Bl]	7.711 Tm
Mechanical resistance [Rms]	2.006 kg/s
Moving mass [Mms]	37.718 g
Compliance [Cms]	0.156 mm/N
Effective diaph. diameter [D]	126.8 mm
Effective piston area [Sd]	126.28 cm ²
Equivalent volume [Vas]	3.5296 l
Sensitivity (2.83V/1m)	87 dB
Ratio Bl/√Re	4.1819 N/√W
Ratio fs/Qts	82.183 Hz

Electrical Data

Nominal impedance [Zn]	4 Ω
Minimum impedance [Zmin]	3.974 Ω
Maximum impedance [Zo]	23.202 Ω
DC resistance [Re]	3.40 Ω
Voice coil inductance [Le]	0.914 mH

Power Handling

100h RMS noise test (IEC 17.1)	40 W
Long-term max power (IEC 17.3)	- W

Voice Coil & Magnet Data

Voice coil diameter	30.5 mm
Voice coil height	14.4 mm
Voice coil layers	4
Height of gap	6 mm
Linear excursion	± 4.2 mm
Max mech. excursion	± - mm
Unit weight	1.168 kg

