

3", Steel Frame  
0.7" PESVW Voice Coil, Aluminum Former  
Aramid Cone, Rubber Surround  
Ferrite Magnet Motor System  
PP Center Cap

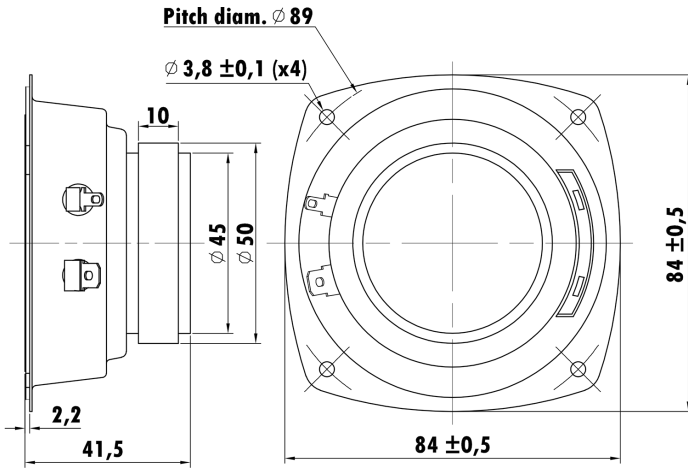

Discontinued

### T-S Parameters

Resonance frequency [fs]	462 Hz
Mechanical Q factor [Qms]	0.533
Electrical Q factor [Qes]	3.799
Total Q factor [Qts]	0.468
Force factor [Bl]	3.112 Tm
Mechanical resistance [Rms]	8.254 kg/s
Moving mass [Mms]	1.517 g
Compliance [Cms]	0.078 mm/N
Effective diaph. diameter [D]	64 mm
Effective piston area [Sd]	32.17 cm <sup>2</sup>
Equivalent volume [Vas]	0.1146 l
Sensitivity (2.83V/1m)	76 dB
Ratio Bl/√Re	1.08 N/√W
Ratio fs/Qts	987 Hz

### Electrical Data

Nominal impedance [Zn]	8 Ω
Minimum impedance [Zmin]	8.2 Ω
Maximum impedance [Zo]	9.37 Ω
DC resistance [Re]	8.36 Ω
Voice coil inductance [Le]	0.156 mH

### Power Handling

100h RMS noise test (IEC 18.4)	10 W
Long-term max power (IEC 18.2)	- W

### Voice Coil & Magnet Data

Voice coil diameter	18.4 mm
Voice coil height	6.5 mm
Voice coil layers	2
Height of gap	3 mm
Linear excursion	± 1.75 mm
Max mech. excursion	± - mm
Unit weight	0.195 kg

