

1.75" x 3", Plastic Frame
0.6" CCAW Voice Coil, Kapton Former
Paper Cone, PU Surround
Neodymium Magnet Motor System

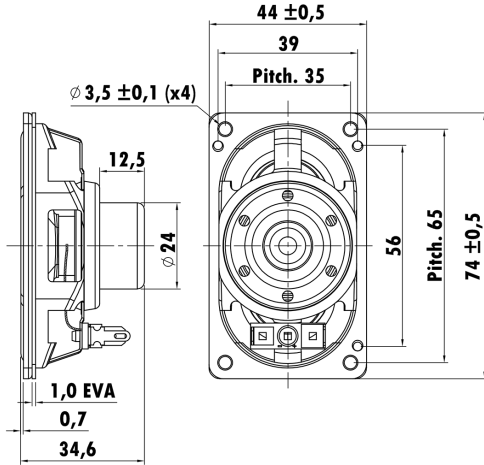

T-S Parameters

Resonance frequency [fs]	167.2 Hz
Mechanical Q factor [Qms]	6.576
Electrical Q factor [Qes]	2.426
Total Q factor [Qts]	1.772
Force factor [Bl]	1.775 Tm
Mechanical resistance [Rms]	0.205 kg/s
Moving mass [Mms]	1.28 g
Compliance [Cms]	0.707 mm/N
Effective diaph. diameter [D]	30x59 mm
Effective piston area [Sd]	17.32 cm ²
Equivalent volume [Vas]	0.299 l
Sensitivity (2.83V/1m)	82 dB
Ratio Bl/√Re	0.745 N/√W
Ratio fs/Qts	94.3 Hz

Electrical Data

Nominal impedance [Zn]	6 Ω
Minimum impedance [Zmin]	5.44 Ω
Maximum impedance [Zo]	12.922 Ω
DC resistance [Re]	5.67 Ω
Voice coil inductance [Le]	0.12 mH

Power Handling

100h RMS noise test (IEC 17.1)	8 W
Long-term max power (IEC 17.3)	30 W

Voice Coil & Magnet Data

Voice coil diameter	16.28 mm
Voice coil height	6.8 mm
Voice coil layers	2
Height of gap	3 mm
Linear excursion	± 1.9 mm
Max mech. excursion	± - mm
Unit weight	0.061 kg

