

3", Steel Frame
0.8" CCAW Voice Coil, Kapton Former
Paper Cone, Rubber Surround
Dual Neodymium Magnet Motor System
Slim Driver
Conference Speaker System

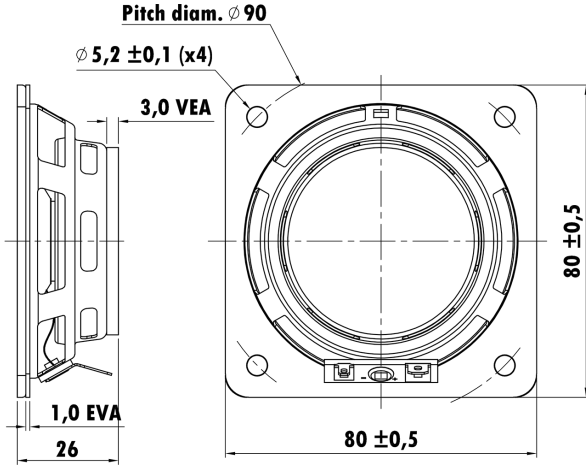

T-S Parameters

Resonance frequency [fs]	196.8 Hz
Mechanical Q factor [Qms]	5.848
Electrical Q factor [Qes]	1.931
Total Q factor [Qts]	1.452
Force factor [Bl]	2.609 Tm
Mechanical resistance [Rms]	0.617 kg/s
Moving mass [Mms]	2.917 g
Compliance [Cms]	0.224 mm/N
Effective diaph. diameter [D]	59 mm
Effective piston area [Sd]	27.34 cm ²
Equivalent volume [Vas]	0.237 l
Sensitivity (2.83V/1m)	84 dB
Ratio Bl/√Re	1.37 N/√W
Ratio fs/Qts	135.5 Hz

Electrical Data

Nominal impedance [Zn]	4 Ω
Minimum impedance [Zmin]	3.9 Ω
Maximum impedance [Zo]	9.7 Ω
DC resistance [Re]	3.6 Ω
Voice coil inductance [Le]	0.05 mH

Voice Coil & Magnet Data

Voice coil diameter	20.32 mm
Voice coil height	5.0 mm
Voice coil layers	2
Height of gap	2.5 mm
Linear excursion	± 1.25 mm
Max mech. excursion	± - mm
Unit weight	0.075 kg

Power Handling

100h RMS noise test (IEC 18.4)	5 W
Long-term max power (IEC 18.2)	6 W

