

90mm x 27mm, Steel Frame
0.5" CCAW Voice Coil, Aluminum Former
Paper Cone, Rubber Surround
Dual Neodymium Magnet Motor System
Rectangular narrow driver
Power Handling with 2th HP Filter @ 120Hz

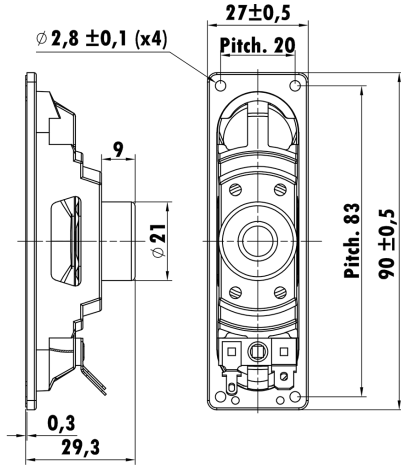

T-S Parameters

Resonance frequency [fs]	238 Hz
Mechanical Q factor [Qms]	3.46
Electrical Q factor [Qes]	1.51
Total Q factor [Qts]	1.05
Force factor [Bl]	3.12 Tm
Mechanical resistance [Rms]	0.55 kg/s
Moving mass [Mms]	1.28 g
Compliance [Cms]	0.34 mm/N
Effective diaph. diameter [D]	75.2 x20 mm
Effective piston area [Sd]	14.18 cm ²
Equivalent volume [Vas]	0.09 l
Sensitivity (2.83V/1m)	82 dB
Ratio Bl/√Re	1.13 N/√W
Ratio fs/Qts	226.6 Hz

Electrical Data

Nominal impedance [Zn]	8 Ω
Minimum impedance [Zmin]	6.8 Ω
Maximum impedance [Zo]	20.7 Ω
DC resistance [Re]	7.6 Ω
Voice coil inductance [Le]	0.19 mH

Power Handling

100h RMS noise test (IEC 18.4)	20 W
Long-term max power (IEC 18.2)	- W

Voice Coil & Magnet Data

Voice coil diameter	13.28 mm
Voice coil height	4.4 mm
Voice coil layers	4
Height of gap	2 mm
Linear excursion	± 1.2 mm
Max mech. excursion	± - mm
Unit weight	0.0392 kg

