

2", Steel Frame
 0.6"PESVW Voice Coil, Kapton Former
 Paper Cone,Rubber Surround
 Dual Neodymium Magnet Motor System

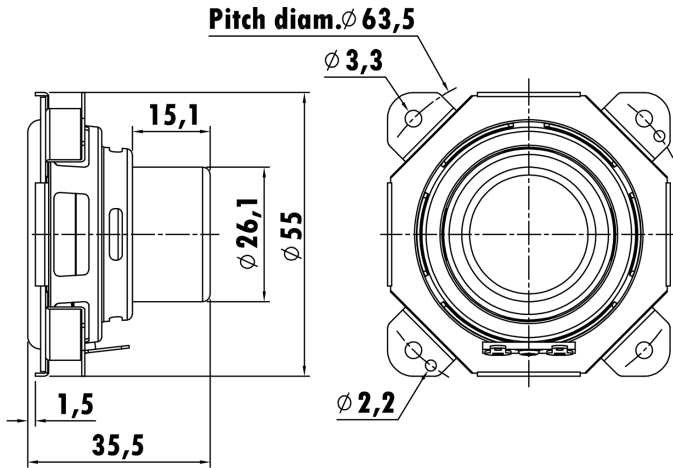

T-S Parameters

Resonance frequency [fs]	156.0 Hz
Mechanical Q factor [Qms]	14.13
Electrical Q factor [Qes]	0.609
Total Q factor [Qts]	0.584
Force factor [Bl]	3.261 Tm
Mechanical resistance [Rms]	0.133 kg/s
Moving mass [Mms]	1.922 g
Compliance [Cms]	0.541 mm/N
Effective diaph. diameter [D]	39.25 mm
Effective piston area [Sd]	12.1 cm ²
Equivalent volume [Vas]	0.1122 l
Sensitivity (2.83V/1m)	83 dB
Ratio Bl/√Re	1.758 N/√W
Ratio fs/Qts	267.12 Hz

Electrical Data

Nominal impedance [Zn]	4 Ω
Minimum impedance [Zmin]	3.689 Ω
Maximum impedance [Zo]	41.275 Ω
DC resistance [Re]	3.44 Ω
Voice coil inductance [Le]	0.149 mH

Power Handling

100h RMS noise test (IEC 17.1)	3 W
Long-term max power (IEC 17.3)	- W

Voice Coil & Magnet Data

Voice coil diameter	19.4 mm
Voice coil height	8.6 mm
Voice coil layers	2
Height of gap	4 mm
Linear excursion	\pm 2.3 mm
Max mech. excursion	\pm - mm
Unit weight	0.085 kg

