

1.5", Plastic Frame
1" CCAW Voice Coil, Aluminum Former
Titanium Dome with Polyurethane Surround
Neodymium Magnet Motor System
Frequency Response Extended to 10 KHz Spider-less

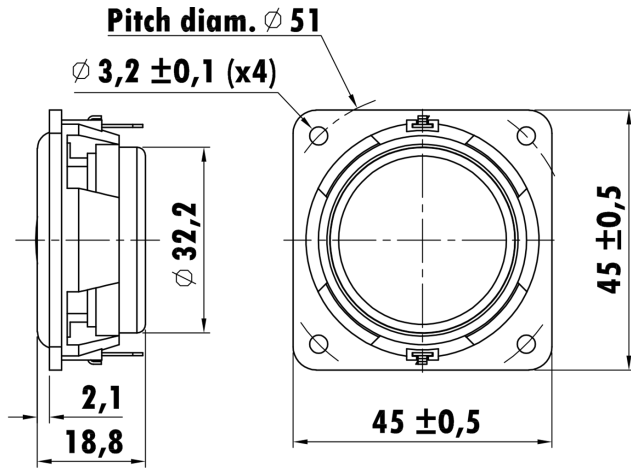

Prototype

T-S Parameters

Resonance frequency [fs]	212 Hz
Mechanical Q factor [Qms]	2.52
Electrical Q factor [Qes]	0.39
Total Q factor [Qts]	0.33
Force factor [Bl]	2.55 Tm
Mechanical resistance [Rms]	0.31 kg/s
Moving mass [Mms]	0.6 g
Compliance [Cms]	0.93 mm/N
Effective diaph. diameter [D]	32.5 mm
Effective piston area [Sd]	8.3 cm ²
Equivalent volume [Vas]	0.09 l
Sensitivity (2.83V/1m)	87 dB
Ratio Bl/√Re	1.425 N/√W
Ratio fs/Qts	642.4 Hz

Electrical Data

Nominal impedance [Zn]	4 Ω
Minimum impedance [Zmin]	3.6 Ω
Maximum impedance [Zo]	16.24 Ω
DC resistance [Re]	3.2 Ω
Voice coil inductance [Le]	0.05 mH

Power Handling

100h RMS noise test (IEC 18.4)	5 W
Long-term max power (IEC 18.2)	5.5 W

Voice Coil & Magnet Data

Voice coil diameter	25.4 mm
Voice coil height	2.5 mm
Voice coil layers	3
Height of gap	2.5 mm
Linear excursion	± 0 mm
Max mech. excursion	± - mm
Unit weight	0.0595 kg

